

SPECIFICATION FOR APPROVAL

产品规格书

DESCRIPTION : SMD BUZZER
PART NO. : HYG1625A
USER' S PART NO. :
DATE : 2015. 06. 08
CUSTOMER APPROVED :

Approved By	Checked By	Made By

兴化市华宇电子有限公司

地址：江苏省兴化市陈堡工业区
电话：0523-83723110
传真：0523-83723118
邮箱：China_hydz@163.com
网址：www.js-huayu.com

HYG1625A

DATE:20015.06.08

1 . Electrical Characteristics

VER :.0

Operating Voltage	Max25Vp-p
Current Consumption	Max 2mA at 3Vp-p/Square Wave/4.1KHz
Sound Pressure Level	Min 75dB at 10cm/ 3Vp-p/Square Wave/4.0KHz
Electrostatic Capacity	15000±30%pF at 100Hz/1Vrms
Operating Temperature (°C)	-20~ +70
Storage Temperature (°C)	-30 ~ +80
Dimension	L16×W16×H2.5mm

2 . Typical Frequency Response Curve

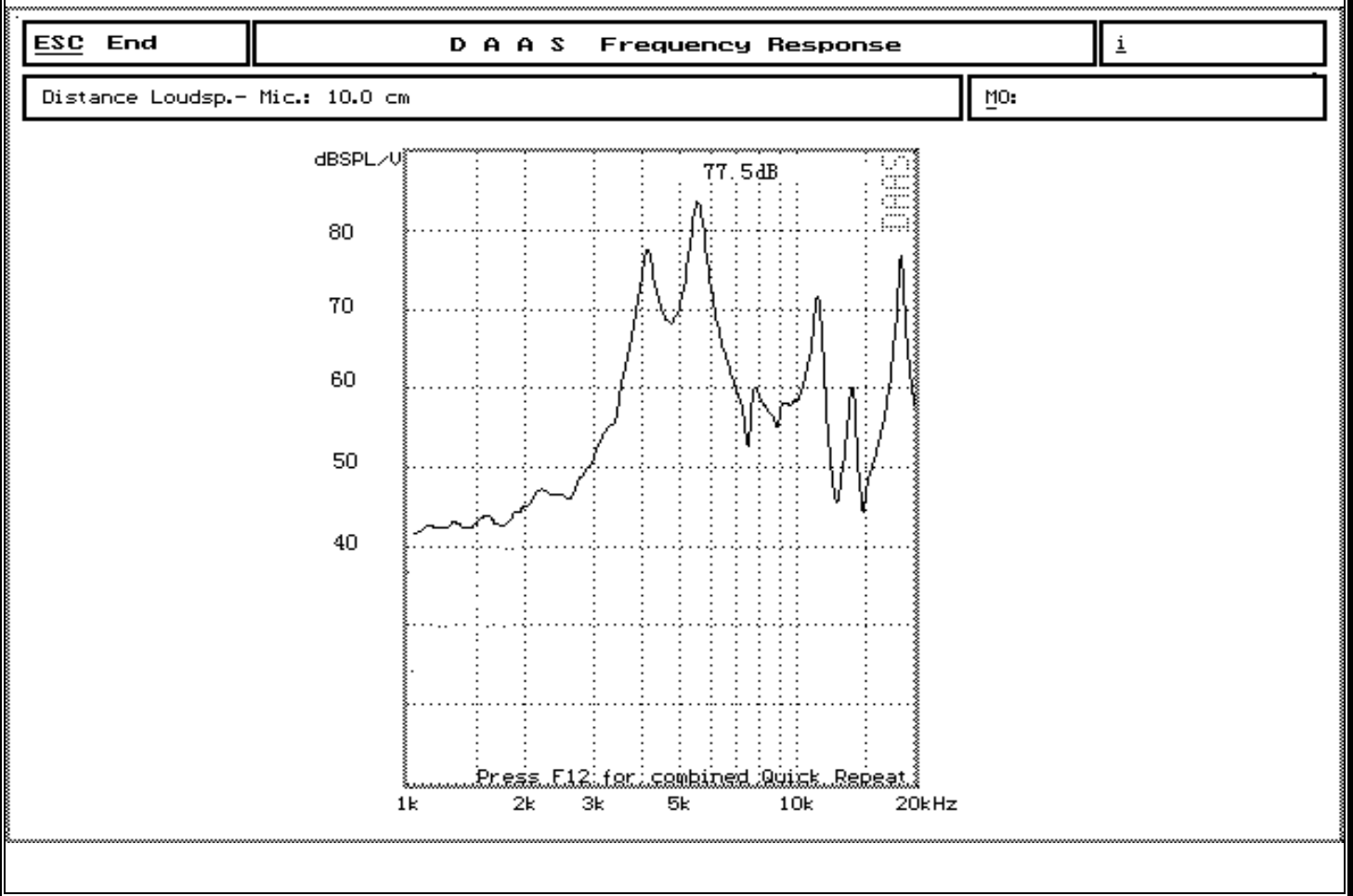

3 . Dimensions and Material

3-1 Shape

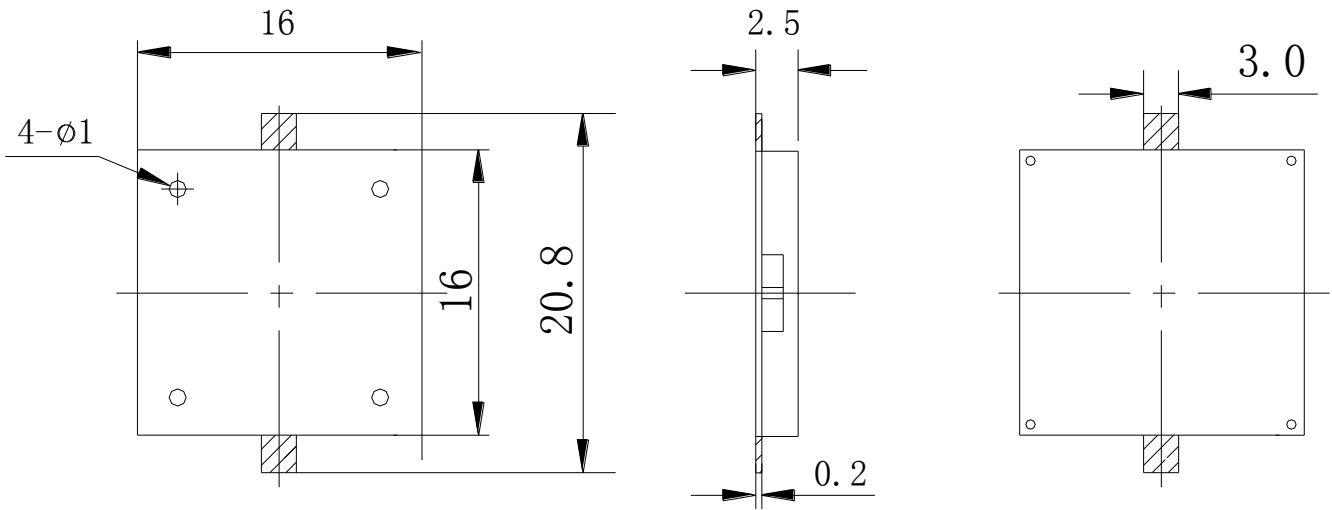

Unit: mm Tol: ± 0.3

3-2 Material

Housing	LCP plastic resin (Color : White)
Terminal	SMD Type
Weight (Gram)	1

4. TESTING METHOD

- **Standard Measurement conditions**

Temperature: $25 \pm 2 \text{ }^\circ\text{C}$ Humidity: 45-60%

- **Acoustic Characteristics**

The oscillation frequency, current consumption and sound pressure are measured by the measuring instruments shown below.

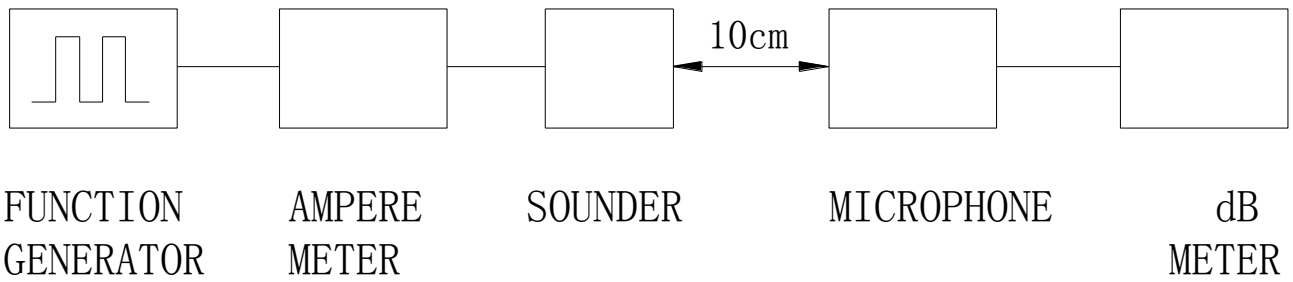

In the measuring test, buzzer is placed as follows:

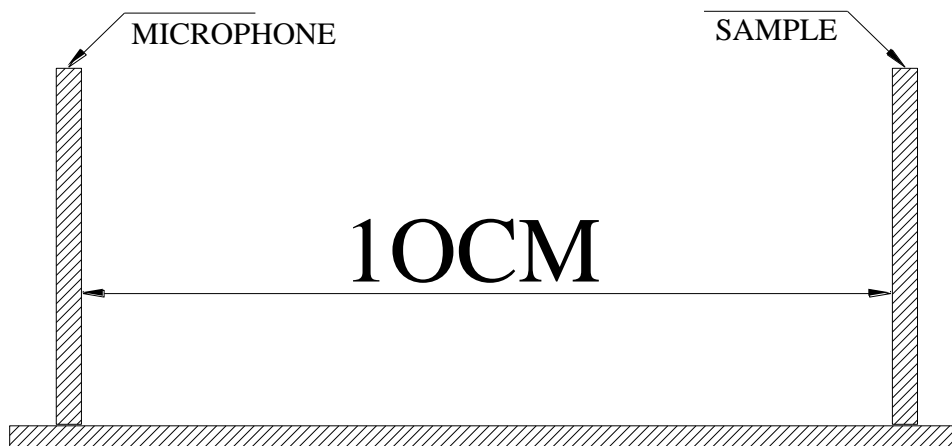

5. RELIABILITY

ITEMS	METHOD OF TEST AND MEASUREMENTS	PERFORMANCE
<i>Coldness withstanding</i>	<i>After 98 hours of being exposed to -30 °C environment, should be returned to normal environment for 2 hours, then re-proceed to test.</i>	<i>No abnormality shall exist</i>
<i>Hotness withstanding</i>	<i>After 98 hours of being exposed to +100 °C environment, should be returned to normal environment for 2 hours, then re-proceed to test.</i>	<i>No abnormality shall exist</i>
<i>Humidity withstanding</i>	<i>After 98 hours of being exposed to 40 °C 95%RH environment in actual operation, should be returned to normal environment for 2 hours, then re-proceed to test.</i>	<i>No abnormality shall exist</i>
<i>Durability</i>	<i>Testing after 1,000 hours actual continuous operation.(at standard measurement conditions)</i>	<i>No abnormality shall exist</i>
<i>Drop withstanding</i>	<i>A natural drop from 75cm high down to the ground.</i>	<i>No abnormality shall exist</i>
<i>Vibration withstanding</i>	<i>Vibration of 2,000 cycles per minute, 2mm amplitude, applied in X, Y and Z directions for 30 minutes each.</i>	<i>No abnormality shall exist</i>

6. Soldering Condition

(1) Recommendable reflow soldering condition is as follows
(Reflow soldering is twice)

Note: It is requested that reflow soldering should be executed after heat of product goes down to normal.

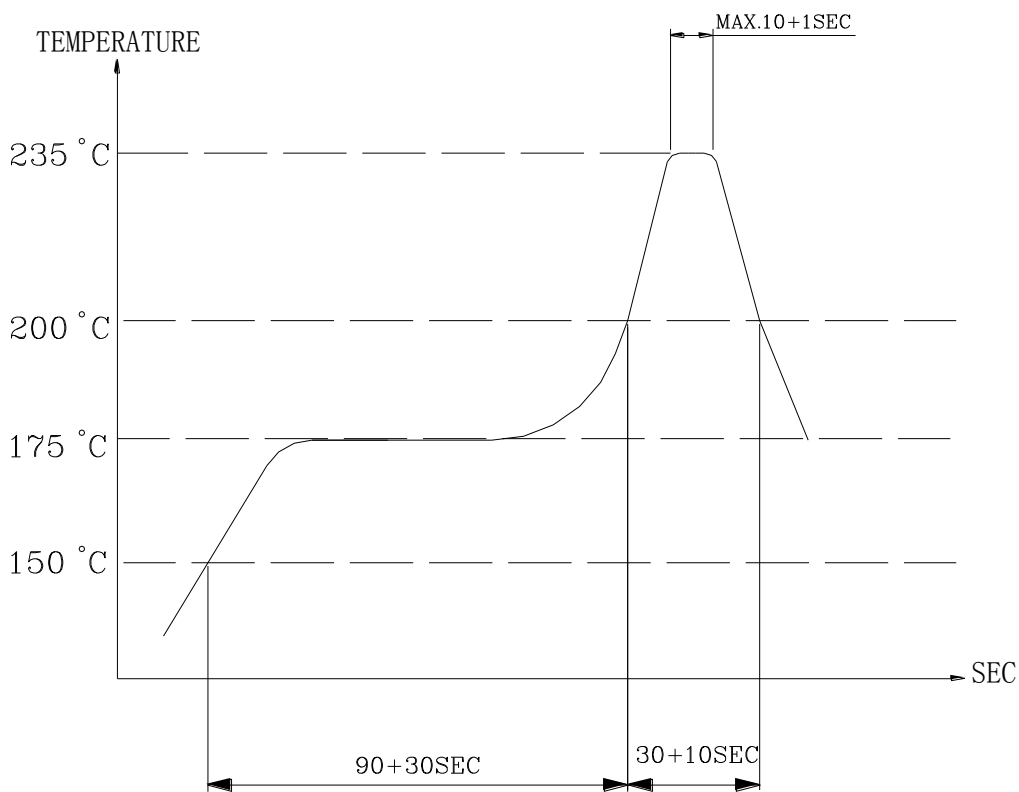

Heat resistant line

(Used when heat resistant reliability test is performed)

(2) Manual soldering

Manual soldering temperature 350 C within 10 sec.

8.PACKAGE METHOD

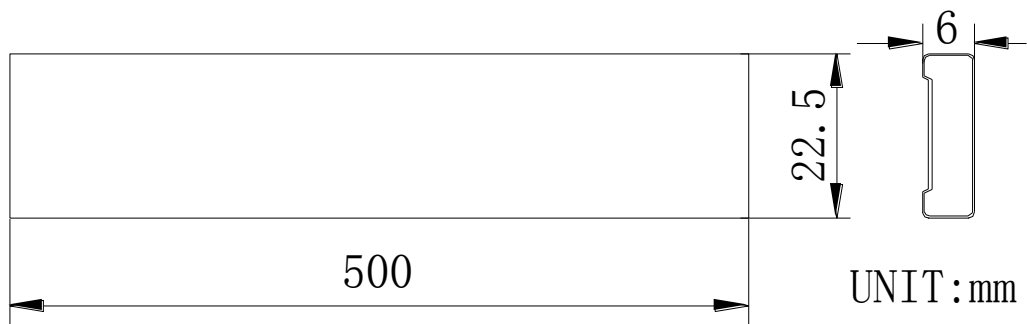

A plastics packing pack 30PCS BUZZER

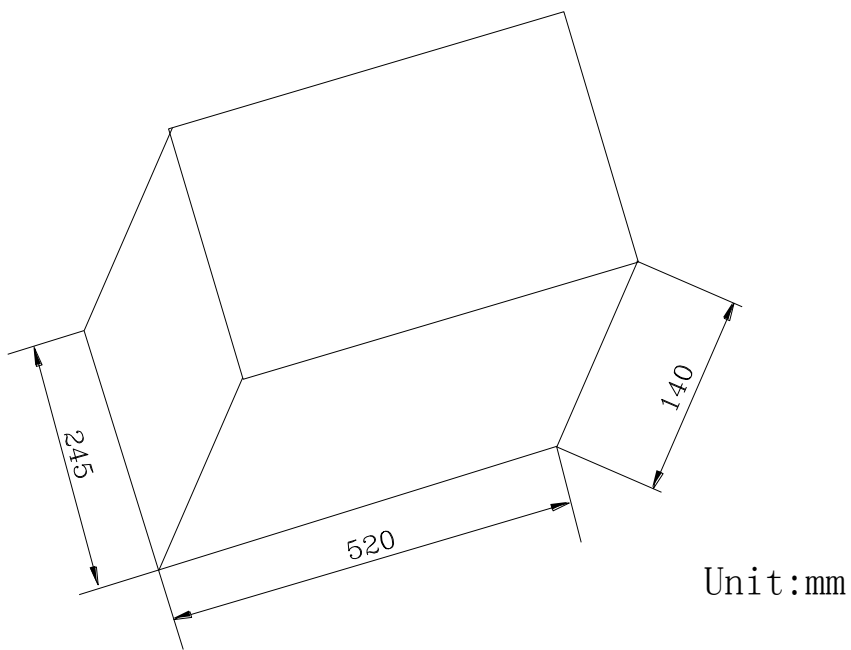

200 plastics packing pack Inner box 6000PCS